

US008729796B2

(12) **United States Patent**  
**Choi et al.**

(10) **Patent No.:** **US 8,729,796 B2**  
(45) **Date of Patent:** **May 20, 2014**

(54) **ORGANIC LIGHT EMITTING DISPLAY  
DEVICE INCLUDING A GAP TO IMPROVE  
IMAGE QUALITY AND METHOD OF  
FABRICATING THE SAME**

4,826,297 A 5/1989 Kubo et al.  
4,984,059 A 1/1991 Kubota et al.  
5,610,742 A 3/1997 Hinata et al.

(Continued)

(75) Inventors: **Dong-Soo Choi**, Suwon-si (KR);  
**Jin-Woo Park**, Suwon-si (KR);  
**Hee-Seong Jeong**, Suwon-si (KR);  
**Hyun-Sook Park**, Suwon-si (KR)

FOREIGN PATENT DOCUMENTS

CN 1290121 A 4/2001  
CN 1438825 8/2003

(Continued)

(73) Assignee: **Samsung Display Co., Ltd.**, Yongin,  
Gyeonggi-Do (KR)

OTHER PUBLICATIONS

Machine translation of JP10-0745883 published Mar. 17, 1998.\*

(\* ) Notice: Subject to any disclaimer, the term of this  
patent is extended or adjusted under 35  
U.S.C. 154(b) by 399 days.

(Continued)

*Primary Examiner* — Britt D Hanley

(21) Appl. No.: **11/529,891**

(74) *Attorney, Agent, or Firm* — Knobbe Martens Olson &  
Bear LLP

(22) Filed: **Sep. 29, 2006**

(57) **ABSTRACT**

(65) **Prior Publication Data**

US 2007/0170855 A1 Jul. 26, 2007

(51) **Int. Cl.**  
**H01L 51/50** (2006.01)  
**H01L 51/52** (2006.01)

(52) **U.S. Cl.**  
CPC ..... **H01L 51/5246** (2013.01); **H01L 51/5281**  
(2013.01)

USPC ..... **313/512**; 313/504

(58) **Field of Classification Search**  
CPC ..... H01L 51/5246; H01L 51/5281  
See application file for complete search history.

Provided is an organic light emitting display device (OLED) for preventing Newton's rings to improve image quality. An organic light emitting display device according to one embodiment of the present invention comprises a first substrate comprising a single layer or multiple layers; a second substrate comprising a single layer or multiple layers, the second substrate comprising an inner surface facing the first substrate; an array of organic light emitting pixels formed on the first substrate and interposed between the first and second substrates, the array comprising a top surface opposing the inner surface of the second substrate, wherein the top surface and the inner surface has a gap therebetween, and the gap has a gap distance measured between the top surface and the inner surface; and a frit seal interconnecting the first and second substrates while surrounding the array, wherein the frit seal, the first substrate and the second substrate in combination define an enclosed space in which the array is located, wherein the frit seal has a height between the first and second substrates so as to form the gap distance equal to or greater than about 10 μm.

(56) **References Cited**

U.S. PATENT DOCUMENTS

3,966,449 A 6/1976 Foster  
4,004,936 A 1/1977 Powell  
4,105,292 A 8/1978 Conder et al.  
4,238,704 A 12/1980 Bonk et al.  
4,702,566 A 10/1987 Tukude

**20 Claims, 7 Drawing Sheets**

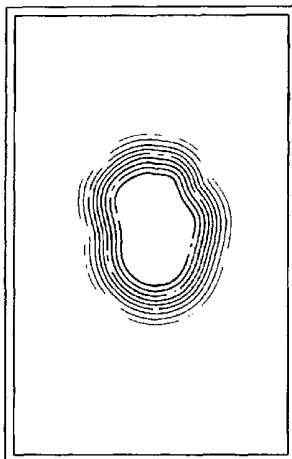

(56)

## References Cited

## U.S. PATENT DOCUMENTS

5,687,465	A	11/1997	Hinata et al.	7,425,166	B2	9/2008	Burt et al.
5,808,719	A	9/1998	Fujiwara et al.	7,425,518	B2	9/2008	Yoshida et al.
5,811,927	A	9/1998	Anderson et al.	7,426,010	B2	9/2008	Lee et al.
5,965,907	A	10/1999	Huang et al.	7,452,738	B2	11/2008	Hayashi et al.
6,005,653	A	12/1999	Matsuzawa	7,474,375	B2	1/2009	Kwak et al.
6,057,647	A *	5/2000	Kurosawa et al. .... 313/506	7,498,186	B2	3/2009	Lee
6,087,717	A	7/2000	Ano et al.	7,514,280	B2	4/2009	Lee
6,195,142	B1	2/2001	Gyotoku et al.	7,528,544	B2	5/2009	Kwak et al.
6,210,815	B1	4/2001	Ooishi	7,537,504	B2	5/2009	Becken et al.
6,211,938	B1	4/2001	Mori	7,564,185	B2	7/2009	Song et al.
6,236,444	B1	5/2001	Konuma et al.	7,579,203	B2	8/2009	Yamazaki et al.
6,288,487	B1	9/2001	Arai	7,579,220	B2	8/2009	Ohnuma et al.
6,424,009	B1	7/2002	Ju	7,585,022	B2	9/2009	Achilles et al.
6,452,323	B1	9/2002	Byrum et al.	7,586,254	B2	9/2009	Kwak et al.
6,472,087	B1	10/2002	Otani et al.	7,597,603	B2	10/2009	Becken et al.
6,489,719	B1	12/2002	Young et al.	7,821,197	B2	10/2010	Lee
6,495,262	B2	12/2002	Igeta	7,825,594	B2	11/2010	Lee et al.
6,515,417	B1	2/2003	Duggal et al.	7,834,550	B2	11/2010	Lee et al.
6,551,724	B2	4/2003	Ishii et al.	7,837,530	B2	11/2010	Park
6,554,672	B2	4/2003	Dunham et al.	7,944,143	B2	5/2011	Choi et al.
6,555,025	B1	4/2003	Krupetsky et al.	8,038,495	B2	10/2011	Lee et al.
6,565,400	B1	5/2003	Lee et al.	2001/0030730	A1	10/2001	Iwanaga et al.
6,590,337	B1	7/2003	Nishikawa et al.	2002/0024051	A1	2/2002	Yamazaki et al.
6,603,254	B1	8/2003	Ando	2003/0066311	A1	4/2003	Li et al.
6,605,826	B2	8/2003	Yamazaki et al.	2003/0077396	A1	4/2003	Lecompte et al.
6,624,572	B1	9/2003	Kim et al.	2003/0184221	A1 *	10/2003	Mishima ..... 313/512
6,646,284	B2	11/2003	Yamazaki et al.	2003/0222061	A1	12/2003	Langer et al.
6,650,392	B2	11/2003	Iwanaga et al.	2003/0227252	A1	12/2003	Ikeya et al.
6,660,547	B2	12/2003	Guenther	2004/0069017	A1	4/2004	Li et al.
6,671,029	B1	12/2003	Choi	2004/0075380	A1	4/2004	Takemoto et al.
6,717,052	B2	4/2004	Wang et al.	2004/0104655	A1	6/2004	Kodera et al.
6,744,199	B1	6/2004	Tanaka	2004/0135520	A1	7/2004	Park et al.
6,791,660	B1	9/2004	Hayashi et al.	2004/0169033	A1	9/2004	Kuibira et al.
6,831,725	B2	12/2004	Niira	2004/0169174	A1	9/2004	Huh et al.
6,833,668	B1	12/2004	Yamada et al.	2004/0201348	A1	10/2004	Anandan
6,861,801	B2	3/2005	Kim et al.	2004/0206953	A1 *	10/2004	Morena et al. .... 257/40
6,878,467	B2	4/2005	Chung et al.	2004/0207314	A1	10/2004	Aitken et al.
6,896,572	B2	5/2005	Park et al.	2005/0046338	A1 *	3/2005	Park ..... 313/504
6,914,661	B2	7/2005	Masuda et al.	2005/0088595	A1	4/2005	Akiyama et al.
6,924,594	B2	8/2005	Ogura et al.	2005/0092927	A1	5/2005	Nagano
6,936,963	B2	8/2005	Langer et al.	2005/0110404	A1 *	5/2005	Park et al. .... 313/512
6,956,324	B2	10/2005	Yamazaki	2005/0127820	A1	6/2005	Yamazaki et al.
6,956,638	B2	10/2005	Akiyama et al.	2005/0218396	A1	10/2005	Tsuchiya et al.
6,965,195	B2	11/2005	Yamazaki et al.	2005/0231107	A1	10/2005	Yamazaki et al.
6,980,275	B1	12/2005	Konuma et al.	2005/0233885	A1	10/2005	Yoshida et al.
6,993,537	B2	1/2006	Buxton et al.	2005/0248270	A1	11/2005	Ghosh et al.
6,998,776	B2 *	2/2006	Aitken et al. .... 313/512	2005/0275342	A1	12/2005	Yanagawa
7,023,518	B1	4/2006	Koyama et al.	2006/0082298	A1	4/2006	Becken et al.
7,030,558	B2	4/2006	Park et al.	2006/0084348	A1 *	4/2006	Becken et al. .... 445/25
7,098,589	B2	8/2006	Erchak et al.	2006/0284556	A1	12/2006	Tremel et al.
7,112,115	B1	9/2006	Yamazaki et al.	2006/0290261	A1	12/2006	Sawai et al.
7,141,925	B2	11/2006	Wittmann et al.	2007/0120478	A1	5/2007	Lee et al.
7,154,218	B2	12/2006	Murakami et al.	2007/0170324	A1	7/2007	Lee et al.
7,178,927	B2	2/2007	Seo	2007/0170423	A1	7/2007	Choi et al.
7,186,020	B2	3/2007	Taya et al.	2007/0170605	A1	7/2007	Lee et al.
7,187,121	B2	3/2007	Hasegawa et al.	2007/0170839	A1	7/2007	Choi et al.
7,193,218	B2	3/2007	Nagano	2007/0170845	A1	7/2007	Choi et al.
7,193,364	B2	3/2007	Klausmann et al.	2007/0170850	A1	7/2007	Choi et al.
7,193,366	B2	3/2007	Tomimatsu et al.	2007/0170857	A1	7/2007	Choi et al.
7,202,602	B2	4/2007	Anandan	2007/0170859	A1	7/2007	Choi et al.
7,211,938	B2	5/2007	Tanaka	2007/0170860	A1	7/2007	Choi et al.
7,214,429	B2	5/2007	Kato et al.	2007/0170861	A1	7/2007	Lee et al.
7,247,986	B2	7/2007	Kang et al.	2007/0171637	A1	7/2007	Choi
7,255,823	B1	8/2007	Guenther et al.	2007/0172971	A1	7/2007	Boroson
7,291,977	B2	11/2007	Kim et al.	2007/0173167	A1	7/2007	Choi
7,306,346	B2	12/2007	Fukuoka et al.	2007/0176549	A1	8/2007	Park
7,317,281	B2	1/2008	Hayashi et al.	2007/0177069	A1	8/2007	Lee
7,332,858	B2	2/2008	Nomura et al.	2007/0197120	A1	8/2007	Lee
7,342,357	B2	3/2008	Sakano et al.	2007/0232182	A1	10/2007	Park
7,344,901	B2	3/2008	Hawtof et al.	2008/0057260	A1	3/2008	Buchhauser et al.
7,359,021	B2	4/2008	Ota et al.	2008/0074036	A1	3/2008	Wang et al.
7,371,143	B2	5/2008	Becken et al.				
7,393,257	B2	7/2008	Spencer et al.				
7,407,423	B2	8/2008	Aitken et al.				
7,423,375	B2	9/2008	Guenther et al.				

## FOREIGN PATENT DOCUMENTS

CN	1459996 (A)	12/2003
CN	1551686 A	12/2004
CN	1577413	2/2005
CN	1592508 (A)	3/2005
CN	161636	5/2005

(56)

## References Cited

## FOREIGN PATENT DOCUMENTS

CN	1617636 A	5/2005	KR	10-2003-0044656	6/2003
CN	1212662	7/2005	KR	10-2003-0089447	11/2003
CN	1212662 C	7/2005	KR	10-2004-0011138	2/2004
CN	1670570	9/2005	KR	10-2005-070543	7/2005
EP	1 058 311 A2	12/2000	KR	10-2005-0076664	7/2005
EP	1 582 914 A1	10/2005	KR	10-2005-0112318	11/2005
EP	1 777 748	4/2007	KR	10-2005-0115408	12/2005
JP	030-37933	2/1991	KR	10-2006-0005369 A	1/2006
JP	04-147217	5/1992	KR	10-2006-0006148	1/2006
JP	04-301879	10/1992	KR	10-2006-0006149	1/2006
JP	06-34983	2/1994	KR	10-2006-0007025	1/2006
JP	06-337429	10/1994	KR	10-2006-0007353	1/2006
JP	07-74583	3/1995	KR	10-2006-0007354	1/2006
JP	09-258671 A *	3/1997	KR	10-2006-0007889	1/2006
JP	09-278483	10/1997	KR	10-2006-0007890	1/2006
JP	10-74583	3/1998	KR	10-2006-0007892	1/2006
JP	10-074583	3/1998	KR	10-2006-0007893	1/2006
JP	10-125463	5/1998	KR	10-2006-0007962	1/2006
JP	10-161137	6/1998	KR	10-2006-0007963	1/2006
JP	63-163423	7/1998	KR	10-2006-0008462	1/2006
JP	10-201585	8/1998	KR	10-2006-0008463	1/2006
JP	11-007031	1/1999	KR	10-2006-0008464	1/2006
JP	11-202349	7/1999	KR	10-2006-0008761	1/2006
JP	2000-173780 (A)	6/2000	KR	10-2006-0008769	1/2006
JP	2001-022293	1/2001	KR	10-2006-0011831	2/2006
JP	2001-052858	2/2001	KR	10-2006-0016188	2/2006
JP	2001-55527	2/2001	KR	10-2006-0016316	2/2006
JP	2001-203076	2/2001	KR	10-2006-0016446	2/2006
JP	2001-110564	4/2001	KR	10-2006-0016856	2/2006
JP	2001-155855 (A)	6/2001	KR	10-2006-0016857	2/2006
JP	2001-230072	8/2001	KR	10-2006-0020109	3/2006
JP	2001-319775	11/2001	KR	10-2006-0025755	3/2006
JP	2002 020169	1/2002	KR	10-2006-0026816	3/2006
JP	2002-93576	3/2002	KR	10-2006-0027321	3/2006
JP	2002-100472	4/2002	KR	10-2006-0028571	3/2006
JP	2002 117777	4/2002	KR	10-2006-0035455	4/2006
JP	2002 170664	6/2002	TW	508976	11/2002
JP	2002-216951	8/2002	TW	517356 (B)	1/2003
JP	2002-280169	9/2002	TW	564563	12/2003
JP	2002-318547	10/2002	TW	569166	1/2004
JP	2001-324662	11/2002	TW	I227094	1/2005
JP	2002-359070	12/2002	TW	I228686	3/2005
JP	2003-123966	4/2003	TW	VI237218	8/2005
JP	2003-228302	8/2003	TW	200541379	12/2005
JP	2003 243160	8/2003	TW	200541382	12/2005
JP	2003 297552	10/2003	TW	200601873	1/2006
JP	2003-332061	11/2003	TW	I1277125	3/2007
JP	2004 29552	1/2004	WO	WO 02/21557	3/2002
JP	2004 070351	3/2004	WO	WO 03/005774	1/2003
JP	04-151656	5/2004	WO	WO 2004-095597	4/2004
JP	2004 303733	10/2004	WO	WO 2004/094331	11/2004
JP	2004 319103	11/2004	WO	WO 2004/112160	12/2004
JP	2005-049808	2/2005	WO	WO 2005/050751	6/2005
JP	2005-71984	3/2005	WO	WO 2006/045067	4/2006
JP	2005-112676	4/2005			
JP	2005-510831	4/2005			
JP	2005-123089	5/2005			
JP	2005-134476 (A)	5/2005			
JP	2005 158672	6/2005			
JP	2005 190683	7/2005			
JP	2005-216746	8/2005			
JP	2005-222807	8/2005			
JP	2005 251415	9/2005			
JP	2005 258405	9/2005			
JP	2005-267991 (A)	9/2005			
JP	2005-302707	10/2005			
JP	2005-302738	10/2005			
JP	2005 340020	12/2005			
JP	2006 524419	10/2006			
KR	10-1995-0009817	4/1995			
KR	10-1998-0017583	6/1998			
KR	10-2000-0045292 A	7/2000			
KR	10-2001-0079597	8/2001			
KR	10-2001-0084380	9/2001			
KR	10-2002-0051153	6/2002			

## OTHER PUBLICATIONS

Office Action Issued on Dec. 19, 2008 in Corresponding Chinese Patent Application No. 2007100072531 With its English Translation—13 pages.

Office Action from corresponding Korean Patent Application No. 10-2006-0007963.

Chinese Office Action and English translation in corresponding Patent Application No. 200710000143.2 dated Sep. 26, 2008.

Chinese Office Action issued Oct. 10, 2008 in corresponding Patent Application No. 2007100040808.

Chinese Office Action issued Aug. 1, 2008 Patent Application No. 200710001301.6 with English translation.

Chinese Office Action issued Oct. 10, 2008 in Corresponding Patent Application No. 200710003941.0 with its English translation—11 pages.

Chinese Office Action issued Oct. 10, 2008 in Patent Application No. 200710001782.0.

Chinese Office Action issued on Aug. 1, 2008 in corresponding Patent Application No. 2007100015717 (w/English translation) in 19 pages.

Chinese Rejection Decision issued on May 8, 2009 in the corresponding Patent Application No. 200710004080.8.

(56)

## References Cited

## OTHER PUBLICATIONS

Chinese Office Action issued on Jan. 8, 2010 in corresponding Patent Application No. 200710003941.0.

European Search Report from the corresponding European Patent Application No. 07101294.2 dated Jun. 6, 2007.

European Search Report from the corresponding European Patent Application No. 07101295.9 dated May 24, 2007.

Japanese Office Action dated Dec. 1, 2009 for Japanese Patent Application No. 2006-193033, which claims priority of the corresponding Korean priority Application No. 10-2006-0007893.

Japanese Office Action mailed Jun. 30, 2009 for Japanese Application No. 2006-222065.

Japanese Office Action dated Jul. 28, 2009 of the Japanese Patent Application No. 2006-153567, which claims priority of the corresponding Korean priority application No. 10-2006-0008462.

Japanese Office Action for Patent Application No. 2006-1930232 mailed May 19, 2009.

Japanese Office Action issued on May 19, 2009 in the corresponding Japanese Patent Application No. 2006-189628.

Japanese Office Action issued on Oct. 20, 2009 in the corresponding Japanese Patent Application No. 2006-189628.

Japanese Office Action issued on Oct. 27, 2009 in the corresponding Japanese Patent Application No. 2006-256002.

Japanese Office Action re Patent Application No. 2006-193034 mailed May 19, 2009.

Korean Notice of Allowance issued Aug. 2, 2007 in counterpart Korean Patent Application No. 10-2006-0016188.

Korean Notice of Allowance issued Jul. 3, 2007 in counterpart Korean Patent Application No. 10-2006-0035455.

Korean Office Action from corresponding Patent Application No. 10-2006-0006148 dated Sep. 26, 2006.

Korean Office Action from corresponding Patent Application No. 10-2006-0007890, dated Sep. 26, 2006.

Korean Office Action issued Feb. 12, 2007 in counterpart Korean Patent Application No. 10-2006-0035455.

U.S. Office Action dated Feb. 2, 2009 in U.S. Appl. No. 11/529,916.

U.S. Office Action dated Apr. 3, 2009 in U.S. Appl. No. 11/541,055.

U.S. Office Action dated Aug. 19, 2009 in U.S. Appl. No. 11/529,915.

U.S. Office Action dated Dec. 31, 2009 in U.S. Appl. No. 11/541,139.

U.S. Office Action dated Nov. 5, 2009 in U.S. Appl. No. 11/541,047.

U.S. Office Action dated Nov. 28, 2007 in U.S. Appl. No. 11/540,150.

U.S. Office Action dated Aug. 21, 2008 in U.S. Appl. No. 11/540,150.

U.S. Office Action dated Nov. 15, 2007 in U.S. Appl. No. 11/541,009.

U.S. Office Action dated Jun. 19, 2008 in U.S. Appl. No. 11/541,009.

U.S. Office Action dated Dec. 3, 2008 in U.S. Appl. No. 11/541,009.

U.S. Office Action dated Apr. 30, 2009 in U.S. Appl. No. 11/540,151.

U.S. Office Action dated Feb. 11, 2009 in U.S. Appl. No. 11/529,883.

U.S. Office Action dated Jul. 17, 2009 in U.S. Appl. No. 11/529,883.

U.S. Office Action dated Dec. 30, 2009 in U.S. Appl. No. 11/541,048.

U.S. Office Action dated Dec. 8, 2008 in U.S. Appl. No. 11/540,021.

U.S. Office Action dated Apr. 27, 2009 in U.S. Appl. No. 11/540,021.

U.S. Office Action dated Feb. 19, 2009 in U.S. Appl. No. 11/540,024.

U.S. Office Action dated May 4, 2009 in U.S. Appl. No. 11/529,995.

U.S. Office Action dated May 8, 2009 in U.S. Appl. No. 11/540,149.

Japan Office Action dated Jul. 28, 2009 of the Japanese Patent Application No. 2006-153567.

Japan Office Action dated Jul. 28, 2009 of the Japanese Patent Application No. 2006 178508.

Japan Office Action dated Jul. 14, 2009 of the Japanese Patent Application No. 2006-151960.

Japan Office Action dated Jul. 14, 2009 of the Japanese Patent Application No. 2006-165210.

Japanese Office Action issued Sep. 8, 2009 in Japanese Patent Application 2007-011996.

U.S. Appl. No. 11/540,024, filed Sep. 29, 2006, Published as 2007/0170605 on Jul. 26, 2007, and its ongoing prosecution history, including without limitation Office Actions, Amendments, Remarks, and any other potentially relevant documents

U.S. Appl. No. 11/540,149, filed Sep. 20, 2006, Published as 2007/0170324 on Jul. 26, 2007, and its ongoing prosecution history,

including without limitation Office Actions, Amendments, Remarks, and any other potentially relevant documents.

U.S. Appl. No. 11/540,021, filed Sep. 29, 2006, Published as 2007/0170423 on Jul. 26, 2007, and its ongoing prosecution history, including without limitation Office Actions, Amendments, Remarks, and any other potentially relevant documents.

U.S. Appl. No. 11/541,047, filed Sep. 29, 2006, Published as 2007/0170839 on Jul. 26, 2007, and its ongoing prosecution history, including without limitation Office Actions, Amendments, Remarks, and any other potentially relevant documents.

U.S. Appl. No. 11/541,139, filed Sep. 29, 2006, Published as 2007/0170850 on Jul. 26, 2007, and its ongoing prosecution history, including without limitation Office Actions, Amendments, Remarks, and any other potentially relevant documents.

U.S. Appl. No. 11/529,916, filed Sep. 29, 2006, Published as 2007/0170850 on Jul. 26, 2007, and its ongoing prosecution history, including without limitation Office Actions, Amendments, Remarks, and any other potentially relevant documents.

U.S. Appl. No. 11/529,914, filed Sep. 29, 2006, Published as 2007/0170857 on Jul. 26, 2007, and its ongoing prosecution history, including without limitation Office Actions, Amendments, Remarks, and any other potentially relevant documents.

U.S. Appl. No. 11/540,103, filed Sep. 29, 2006, Published as 2007/0170857 on Jul. 26, 2007, and its ongoing prosecution history, including without limitation Office Actions, Amendments, Remarks, and any other potentially relevant documents.

U.S. Appl. No. 11/540,151, filed Sep. 29, 2006, Published as 2007/0170859 on Jul. 26, 2007, and its ongoing prosecution history, including without limitation Office Actions, Amendments, Remarks, and any other potentially relevant documents.

U.S. Appl. No. 11/540,157, filed Sep. 29, 2006, Published as 2007/0170860 on Jul. 26, 2007, and its ongoing prosecution history, including without limitation Office Actions, Amendments, Remarks, and any other potentially relevant documents.

U.S. Appl. No. 11/529,995, filed Sep. 29, 2006, Published as 2007/0171637 on Jul. 26, 2007, and its ongoing prosecution history, including without limitation Office Actions, Amendments, Remarks, and any other potentially relevant documents.

U.S. Appl. No. 11/541,055, filed Sep. 29, 2006, Published as 2007/0173167 on Jul. 26, 2007, and its ongoing prosecution history, including without limitation Office Actions, Amendments, Remarks, and any other potentially relevant documents.

U.S. Appl. No. 11/541,009, filed Sep. 29, 2006, Published as 2007/0167549 on Aug. 2, 2007, and its ongoing prosecution history, including without limitation Office Actions, Amendments, Remarks, and any other potentially relevant documents.

U.S. Appl. No. 11/541,048, filed Sep. 29, 2006, Published as 2007/0177069 on Aug. 2, 2007, and its ongoing prosecution history, including without limitation Office Actions, Amendments, Remarks, and any other potentially relevant documents.

U.S. Appl. No. 11/529,883, filed Sep. 29, 2006, Published as 2007/0197120 on Aug. 23, 2007, and its ongoing prosecution history, including without limitation Office Actions, Amendments, Remarks, and any other potentially relevant documents.

U.S. Appl. No. 11/540,008, filed Sep. 29, 2006, Published as 2007/0232182 on Oct. 4, 2007, and its ongoing prosecution history, including without limitation Office Actions, Amendments, Remarks, and any other potentially relevant documents.

U.S. Appl. No. 11/540,150, filed Sep. 29, 2006, and its ongoing prosecution history, including without limitation Office Actions, Amendments, Remarks, and any other potentially relevant documents.

Japanese Office Action dated Jun. 1, 2010 of the Japanese Patent Application No. 2006-193032, which claims priority of the corresponding Korean priority application No. 10-2006-0006148.

Japanese Office Action dated Jun. 15, 2010 of the Japanese Patent Application No. 2006-151960, which claims priority of the corresponding Korean priority application No. 10-2006-0008761.

Taiwanese Office Action issued Jan. 18, 2010 from corresponding TW Application No. 95145107 (which claims priority to KR App. No. 10-2006-0008463).

Taiwanese Office Action Issued Apr. 2, 2010 from corresponding TW Application No. 95144932.

(56)

**References Cited**

OTHER PUBLICATIONS

U.S. Office Action dated Mar. 29, 2010 in U.S. Appl. No. 11/541,055.  
U.S. Office Action (Advisory Action) dated May 19, 2010 in U.S. Appl. No. 11/529,914.  
U.S. Office Action dated May 25, 2010 in U.S. Appl. No. 11/529,995.  
U.S. Office Action dated Nov. 29, 2010 in U.S. Appl. No. 11/529,916.  
U.S. Office Action dated Aug. 19, 2010 in U.S. Appl. No. 11/529,914.  
European Search Report from the corresponding European Patent Application No. 07250311.3 dated Sep. 24, 2010.  
Japanese Office Action dated Feb. 14, 2012 for Japanese Patent Application No. JP 2006-256002 which shares priority of Korean Patent Application No. KR 10-2006-0007963 with captioned U.S. Appl. No. 11/529,891.  
Taiwanese Office Action dated Dec. 22, 2011 for Taiwanese Patent Application No. TW 096101663 which shares priority of Korean

Patent Application No. KR 10-2006-0007963 with captioned U.S. Appl. No. 11/529,891.  
Office Action dated Aug. 7, 2012 for U.S. Appl. No. 11/540,150, filed Sep. 29, 2006, which is related to captioned U.S. Appl. No. 11/529,891.  
Taiwan Office Action dated Jun. 29, 2012 for Taiwan Patent Application No. TW 096101663 which shares priority of Korean Patent Application No. KR 10-2006-0007963 with captioned U.S. Appl. No. 11/529,891.  
Examination Report dated Nov. 18, 2013 for European Patent Application No. EP 07 250 311.3 which shares priority of Korean Patent Application No. KR 10-2006-0007963 with captioned U.S. Appl. No. 11/529,891.  
U.S. Office Action dated Sep. 17, 2013 in U.S. Appl. No. 13/858,883, filed Apr. 8, 2013.

\* cited by examiner

FIG. 1

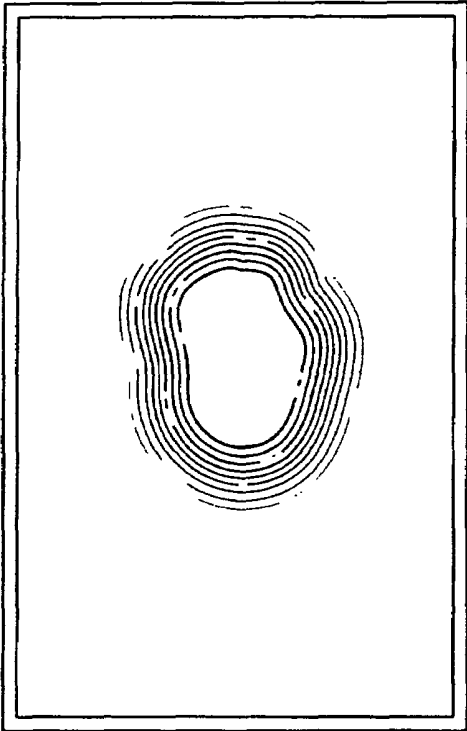

FIG. 2

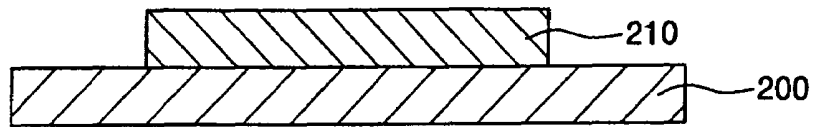

FIG. 3

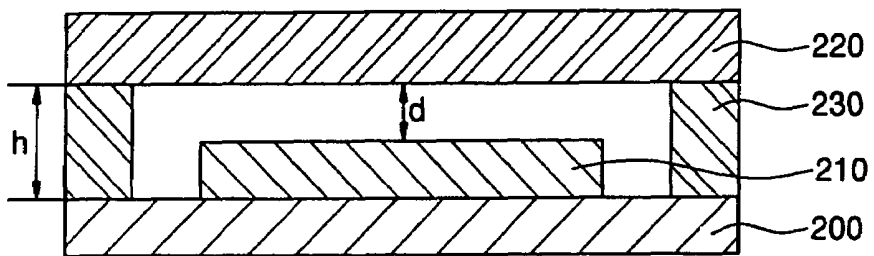

FIG. 4

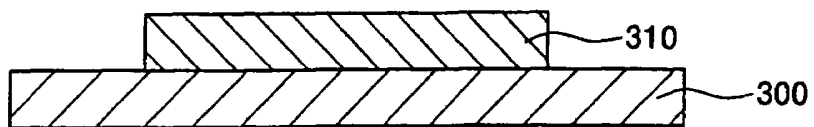

FIG. 5

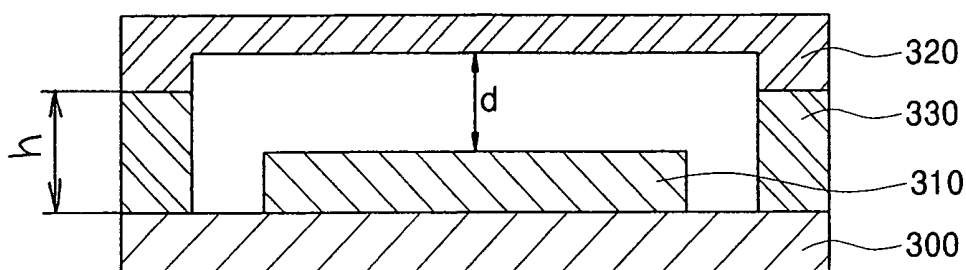

FIG. 6

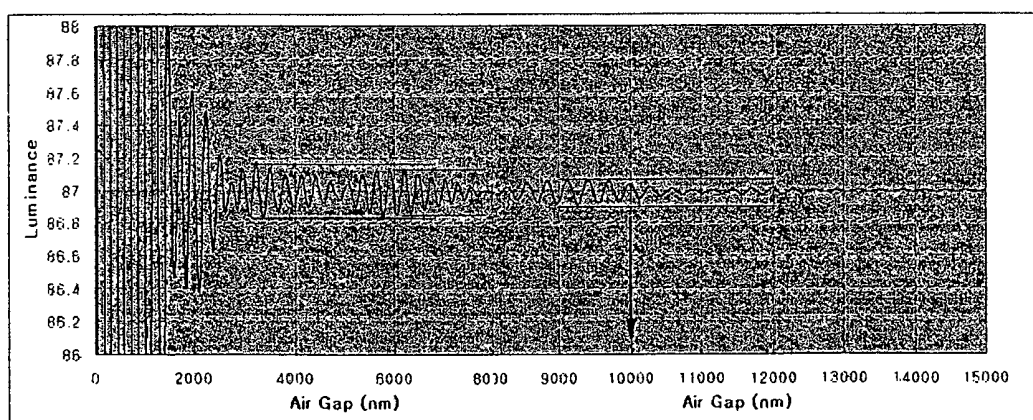

FIG. 7A  
(PRIOR ART)

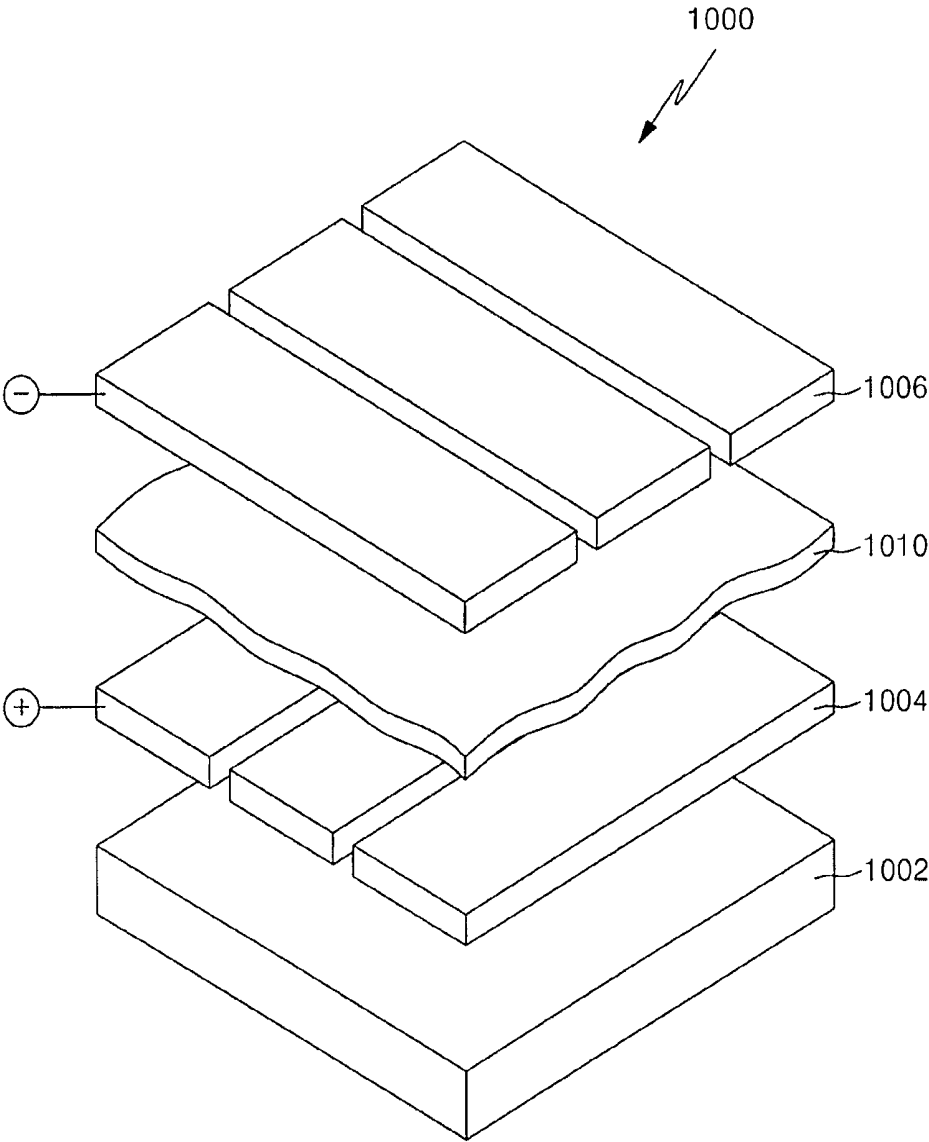

FIG. 7B  
(PRIOR ART)

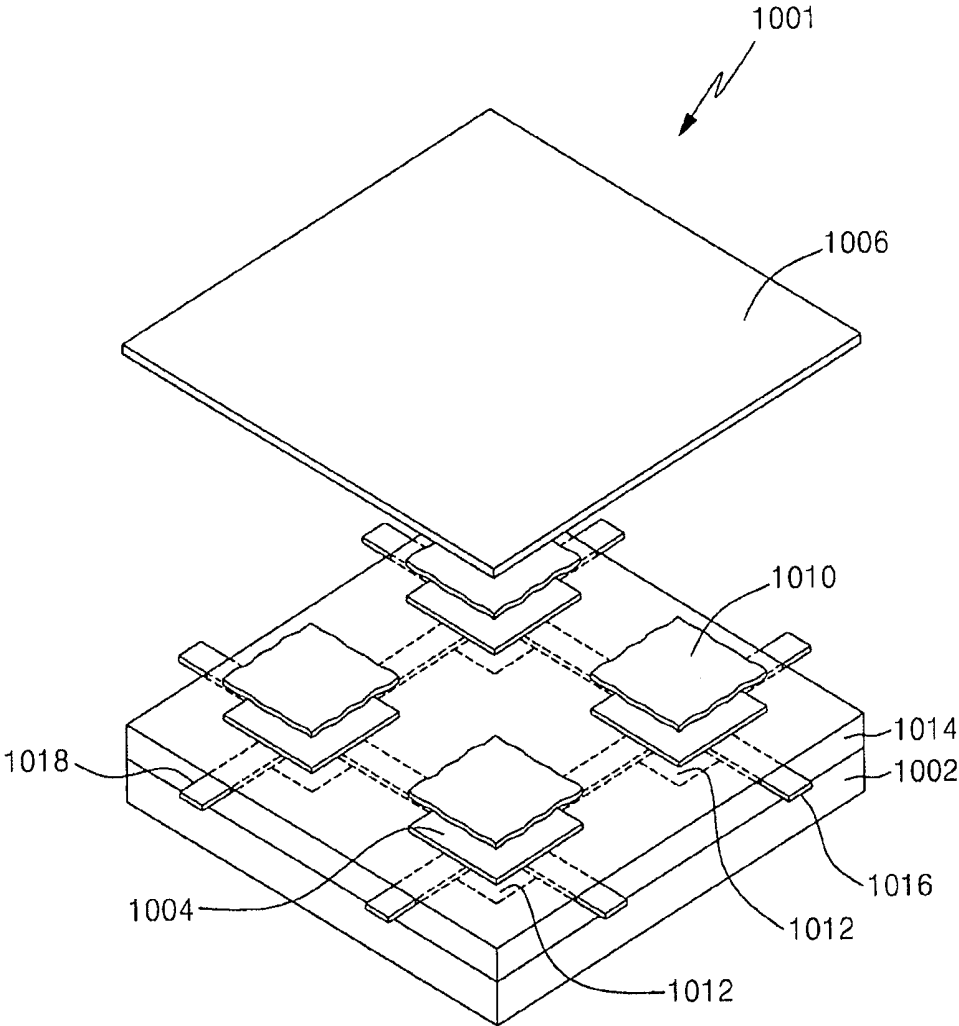

FIG. 7C

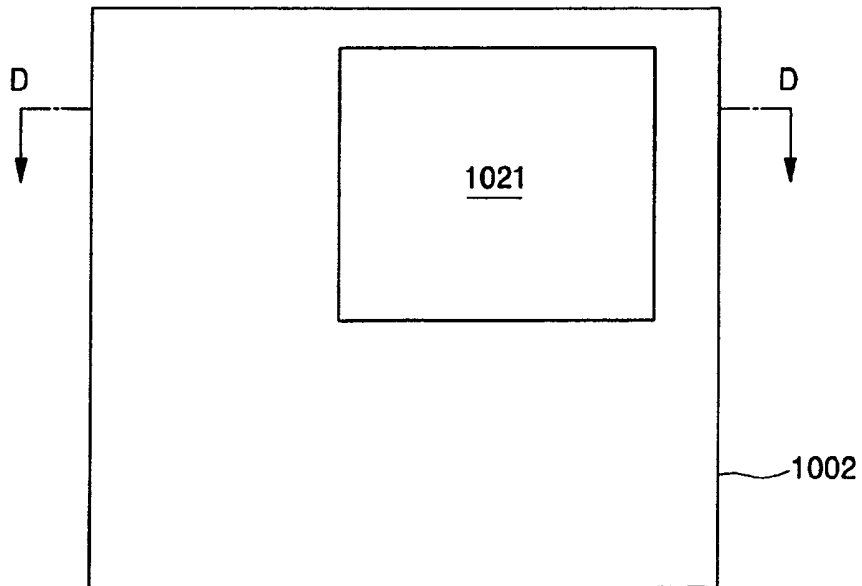

FIG. 7D

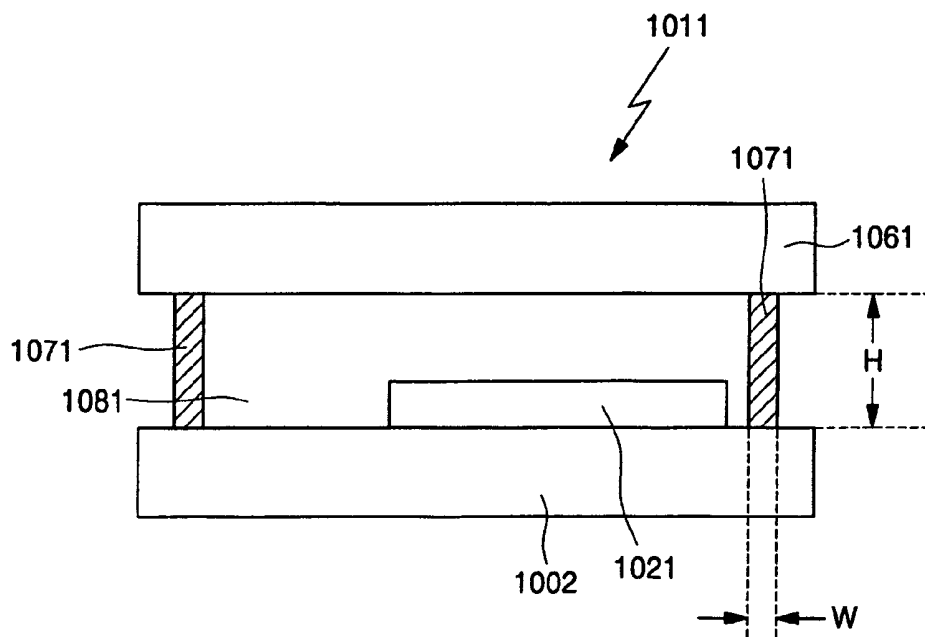
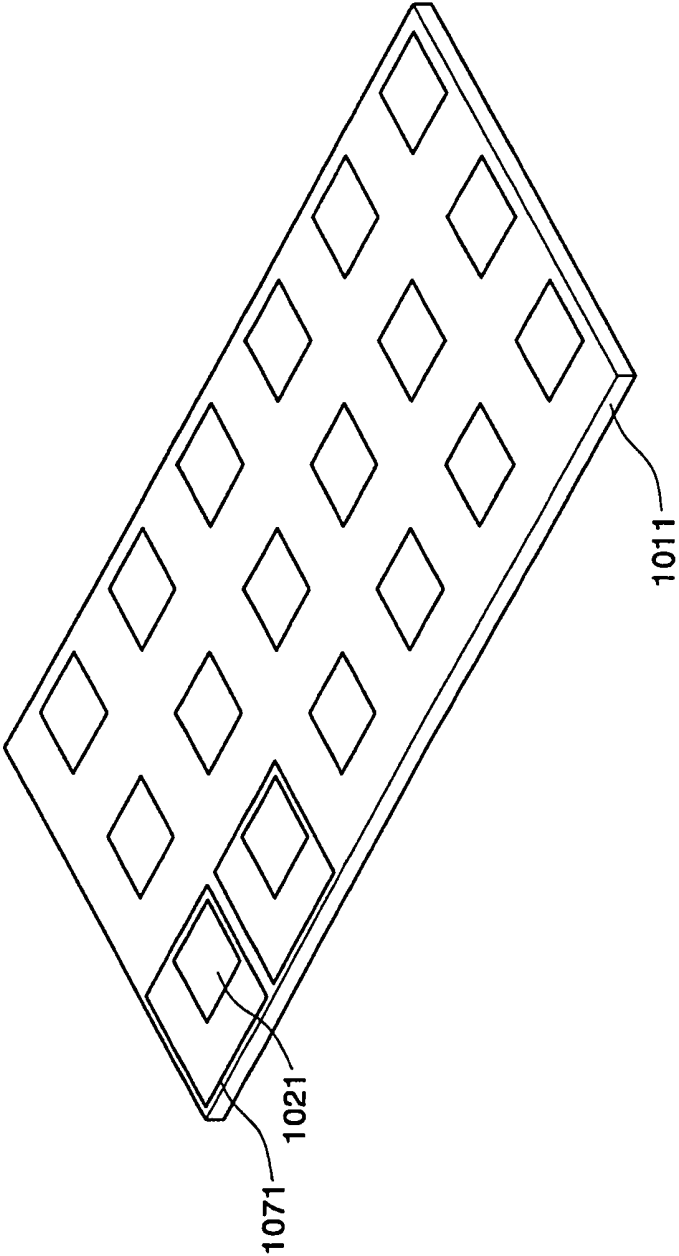

FIG. 7E



**ORGANIC LIGHT EMITTING DISPLAY  
DEVICE INCLUDING A GAP TO IMPROVE  
IMAGE QUALITY AND METHOD OF  
FABRICATING THE SAME**

CROSS-REFERENCE TO RELATED  
APPLICATION

This application claims priority to and the benefit of Korean Patent Application No. 10-2006-0007963, filed Jan. 25, 2006, the disclosure of which is incorporated herein by reference in its entirety. This application is related to and incorporates herein by reference the entire contents of the following concurrently filed applications:

Title	Filing Date	Application No.
ORGANIC LIGHT-EMITTING DISPLAY DEVICE AND METHOD OF FABRICATING THE SAME	Sep. 29, 2006	11/541,055
ORGANIC LIGHT-EMITTING DISPLAY DEVICE AND METHOD OF MANUFACTURING THE SAME	Sep. 29, 2006	11/529,914
ORGANIC LIGHT EMITTING DISPLAY DEVICE	Sep. 29, 2006	11/541,139
ORGANIC LIGHT-EMITTING DISPLAY DEVICE WITH FRIT SEAL AND REINFORCING STRUCTURE	Sep. 29, 2006	11/541,047
ORGANIC LIGHT EMITTING DISPLAY DEVICE METHOD OF FABRICATING THE SAME	Sep. 29, 2006	11/540,150
ORGANIC LIGHT EMITTING DISPLAY AND METHOD OF FABRICATING THE SAME	Sep. 29, 2006	11/541,009
ORGANIC LIGHT-EMITTING DISPLAY DEVICE WITH FRIT SEAL AND REINFORCING STRUCTURE BONDED TO FRAME	Sep. 29, 2006	11/540,151
METHOD FOR PACKAGING ORGANIC LIGHT EMITTING DISPLAY WITH FRIT SEAL AND REINFORCING STRUCTURE	Sep. 29, 2006	11/529,910
METHOD FOR PACKAGING ORGANIC LIGHT EMITTING DISPLAY WITH FRIT SEAL AND REINFORCING STRUCTURE	Sep. 29, 2006	11/540,084
ORGANIC LIGHT-EMITTING DISPLAY DEVICE AND THE PREPARATION METHOD OF THE SAME	Sep. 29, 2006	11/540,008
ORGANIC LIGHT EMITTING DISPLAY AND FABRICATING METHOD OF THE SAME	Sep. 29, 2006	11/541,048
ORGANIC LIGHT-EMITTING DISPLAY AND METHOD OF MAKING THE SAME	Sep. 29, 2006	11/540,021
ORGANIC LIGHT EMITTING DISPLAY AND FABRICATING METHOD OF THE SAME	Sep. 29, 2006	11/540,024
ORGANIC LIGHT EMITTING DISPLAY DEVICE AND MANUFACTURING METHOD THEREOF	Sep. 29, 2006	11/529,995
ORGANIC LIGHT-EMITTING DISPLAY DEVICE AND MANUFACTURING METHOD OF THE SAME	Sep. 29, 2006	11/540,157
ORGANIC LIGHT EMITTING DISPLAY AND FABRICATING METHOD OF THE SAME	Sep. 29, 2006	11/540,149
ORGANIC LIGHT EMITTING DISPLAY AND METHOD OF FABRICATING THE SAME	Sep. 29, 2006	11/529,916
ORGANIC LIGHT EMITTING DISPLAY AND METHOD OF FABRICATING THE SAME	Sep. 29, 2006	11/540,103

## BACKGROUND

## 1. Field of the Invention

The present invention relates to organic light emitting display devices and, more particularly, to packaging such devices.

## 2. Description of the Related Art

In recent years, flat panel display devices (FPDs), such as liquid crystal display devices (LCDs), organic light emitting display devices (OLEDs), and plasma display panels (PDPs), have attracted much attention in order to solve the problems of conventional display devices, such as cathode ray tubes (CRTs). Since the LCD is a non-emissive device, the LCD has technical limits in brightness, contrast, viewing angle, and size. Also, the PDP is an emissive display, but the PDP is heavier, consumes more power, and is more complex to manufacture in comparison with other FPDs.

On the other hand, the OLED is an emissive device that is excellent in viewing angle and contrast. Therefore, the OLED can be made lightweight and thin since a separate light source, i.e., a back light is not required, unlike in the LCD, and consumes less power than the CRT. Furthermore, the OLED can be driven at a low DC voltage and has a fast response speed. Also, since the OLED is fabricated using only solid materials, the OLED is highly resistant to external shock, can be used in a wide range of temperature, and is simple and inexpensive to manufacture.

## SUMMARY OF CERTAIN INVENTIVE ASPECTS

An aspect of the invention provides an organic light emitting display device, which may comprise: a first substrate comprising a single layer or multiple layers; a second substrate comprising a single layer or multiple layers, the second substrate comprising an inner surface facing the first substrate; an array of organic light emitting pixels formed on the first substrate and interposed between the first and second substrates, the array comprising a top surface opposing the inner surface of the second substrate, wherein the top surface and the inner surface has a gap therebetween, and the gap has a gap distance measured between the top surface and the inner surface; and a frit seal interconnecting the first and second substrates while surrounding the array, wherein the frit seal, the first substrate and the second substrate in combination define an enclosed space in which the array is located, wherein the frit seal has a height between the first and second substrates so as to form the gap distance equal to or greater than about 10  $\mu\text{m}$ .

In the foregoing device, the gap distance may be about 10 to about 300  $\mu\text{m}$ . The gap distance may be from about 10 to about 100  $\mu\text{m}$ . The gap distance may be from about 10 to about 30  $\mu\text{m}$ . The array may be configured to emit visible light through the top surface. The height may be the shortest distance between the first and second substrates, wherein the height may be from about 10 to about 300  $\mu\text{m}$ . The second substrate may comprise a display surface facing away from the first substrate and configured to display an image thereon, and wherein the device may be configured to display an image on the display surface substantially free of Newton's rings. The array may comprise a first electrode, a second electrode and at least one organic layer interposed therebetween, wherein the second electrode may be closer to the second substrate than the first electrode, and wherein the top surface may comprise a surface of the second electrode facing the second substrate. The array may comprise a first electrode, a second electrode and at least one organic layer interposed therebetween, wherein the second electrode may be closer to

the second substrate than the first electrode, wherein the array may further comprise a substantially transparent layer formed on the second electrode, and wherein the top surface may comprise a surface of the substantially transparent layer which faces the second substrate. The gap may comprise an air gap. The gap may be substantially filled with a solid material. The frit seal may comprise one or more materials selected from the group consisting of magnesium oxide (MgO), calcium oxide (CaO), barium oxide (BaO), lithium oxide (Li<sub>2</sub>O), sodium oxide (Na<sub>2</sub>O), potassium oxide (K<sub>2</sub>O), boron oxide (B<sub>2</sub>O<sub>3</sub>), vanadium oxide (V<sub>2</sub>O<sub>5</sub>), zinc oxide (ZnO), tellurium oxide (TeO<sub>2</sub>), aluminum oxide (Al<sub>2</sub>O<sub>3</sub>), silicon dioxide (SiO<sub>2</sub>), lead oxide (PbO), tin oxide (SnO), phosphorous oxide (P<sub>2</sub>O<sub>5</sub>), ruthenium oxide (Ru<sub>2</sub>O), rubidium oxide (Rb<sub>2</sub>O), rhodium oxide (Rh<sub>2</sub>O), ferrite oxide (Fe<sub>2</sub>O<sub>3</sub>), copper oxide (CuO), titanium oxide (TiO<sub>2</sub>), tungsten oxide (WO<sub>3</sub>), bismuth oxide (Bi<sub>2</sub>O<sub>3</sub>), antimony oxide (Sb<sub>2</sub>O<sub>3</sub>), lead-borate glass, tin-phosphate glass, vanadate glass, and borosilicate.

Another aspect of the invention provides an organic light emitting display device, which may comprises: a first substrate; a second substrate comprising an inner surface facing the first substrate; and an array of organic light emitting pixels formed on the first substrate, the array comprising a top surface opposing the inner surface of the second substrate, wherein the top surface and the inner surface has a gap therebetween from about 10 to about 300 μm.

In the foregoing device, the device may further comprises a frit seal interconnecting the first and second substrates while surrounding the array, wherein the frit seal, the first substrate and the second substrate in combination may define an enclosed space in which the array is located. The frit seal may have a height between the first and second substrate, and wherein the height is from about 2 to about 300 μm.

Still another aspect of the invention provides a method of making an organic light emitting display device, which may comprise: providing an unfinished device comprising a first substrate and an array of organic light emitting pixels formed on the first substrate, the array comprising a top surface facing away from the first substrate; arranging a second substrate over the unfinished device so as to interpose the array between the first and second substrates with a gap between the top surface and the second substrate, the gap having a gap distance; and forming a frit seal between and interconnecting the first and second substrates while surrounding the array such that the gap distance is equal to or greater than about 10 μm.

In the foregoing method, forming the frit seal may comprise interposing a frit material between the first and second substrate, and bonding the frit material to the first and second substrate so as to form a substantially hermetic seal. Bonding may comprise melting and solidifying the frit material. The frit seal may have a height measured between the first and second substrate, wherein the height may be from about 2 to about 300 μm. The gap distance is about 10 to about 300 μm. The gap distance may be from about 10 to about 30 μm. The second substrate may comprise a display surface facing away from the first substrate and configured to display an image thereon, and wherein the organic light emitting device may be configured to display an image on the display surface substantially free of Newton's rings.

Still in the foregoing method, the unfinished device may further comprise a plurality of additional arrays of organic light emitting pixels formed on the first substrate, wherein the method may further comprise forming a plurality of additional seals between and interconnecting the first and second substrates, wherein a first one of the additional seals may surround a first one of the additional arrays. The first addi-

tional array and the second substrate may form a gap therebetween with a gap distance equal to or greater than about 10 μm. The method may further comprise cutting the unfinished device into two pieces.

#### BRIEF DESCRIPTION OF THE DRAWINGS

The above and other features of the present invention will be described in reference to certain exemplary embodiments thereof with reference to the attached drawings in which:

FIG. 1 is an illustration of Newton's rings in an organic light emitting display device (OLED);

FIGS. 2 and 3 are cross-sectional views of an OLED according to an exemplary embodiment of the present invention;

FIGS. 4 and 5 are cross-sectional views of an OLED according to another exemplary embodiment of the present invention; and

FIG. 6 is a graph of luminance versus an air gap between a substrate and an encapsulation substrate;

FIG. 7A is a schematic exploded view of a passive matrix type organic light emitting display device in accordance with one embodiment;

FIG. 7B is a schematic exploded view of an active matrix type organic light emitting display device in accordance with one embodiment;

FIG. 7C is a schematic top plan view of an organic light emitting display in accordance with one embodiment;

FIG. 7D is a cross-sectional view of the organic light emitting display of FIG. 7C, taken along the line d-d; and

FIG. 7E is a schematic perspective view illustrating mass production of organic light emitting devices in accordance with one embodiment.

#### DETAILED DESCRIPTION OF EMBODIMENTS

The present invention will now be described more fully hereinafter with reference to the accompanying drawings, in which exemplary embodiments of the invention are shown.

An organic light emitting display (OLED) is a display device comprising an array of organic light emitting diodes. Organic light emitting diodes are solid state devices which include an organic material and are adapted to generate and emit light when appropriate electrical potentials are applied.

OLEDs can be generally grouped into two basic types dependent on the arrangement with which the stimulating electrical current is provided. FIG. 7A schematically illustrates an exploded view of a simplified structure of a passive matrix type OLED 1000. FIG. 7B schematically illustrates a simplified structure of an active matrix type OLED 1001. In both configurations, the OLED 1000, 1001 includes OLED pixels built over a substrate 1002, and the OLED pixels include an anode 1004, a cathode 1006 and an organic layer 1010. When an appropriate electrical current is applied to the anode 1004, electric current flows through the pixels and visible light is emitted from the organic layer.

Referring to FIG. 7A, the passive matrix OLED (PMOLED) design includes elongate strips of anode 1004 arranged generally perpendicular to elongate strips of cathode 1006 with organic layers interposed therebetween. The intersections of the strips of cathode 1006 and anode 1004 define individual OLED pixels where light is generated and emitted upon appropriate excitation of the corresponding strips of anode 1004 and cathode 1006. PMOLEDs provide the advantage of relatively simple fabrication.

Referring to FIG. 7B, the active matrix OLED (AMOLED) includes driving circuits 1012 arranged between the substrate

**1002** and an array of OLED pixels. An individual pixel of AMOLEDs is defined between the common cathode **1006** and an anode **1004**, which is electrically isolated from other anodes. Each driving circuit **1012** is coupled with an anode **1004** of the OLED pixels and further coupled with a data line **1016** and a scan line **1018**. In embodiments, the scan lines **1018** supply scan signals that select rows of the driving circuits, and the data lines **1016** supply data signals for particular driving circuits. The data signals and scan signals stimulate the local driving circuits **1012**, which excite the anodes **1004** so as to emit light from their corresponding pixels.

In the illustrated AMOLED, the local driving circuits **1012**, the data lines **1016** and scan lines **1018** are buried in a planarization layer **1014**, which is interposed between the pixel array and the substrate **1002**. The planarization layer **1014** provides a planar top surface on which the organic light emitting pixel array is formed. The planarization layer **1014** may be formed of organic or inorganic materials, and formed of two or more layers although shown as a single layer. The local driving circuits **1012** are typically formed with thin film transistors (TFT) and arranged in a grid or array under the OLED pixel array. The local driving circuits **1012** may be at least partly made of organic materials, including organic TFT. AMOLEDs have the advantage of fast response time improving their desirability for use in displaying data signals. Also, AMOLEDs have the advantages of consuming less power than passive matrix OLEDs.

Referring to common features of the PMOLED and AMOLED designs, the substrate **1002** provides structural support for the OLED pixels and circuits. In various embodiments, the substrate **1002** can comprise rigid or flexible materials as well as opaque or transparent materials, such as plastic, glass, and/or foil. As noted above, each OLED pixel or diode is formed with the anode **1004**, cathode **1006** and organic layer **1010** interposed therebetween. When an appropriate electrical current is applied to the anode **1004**, the cathode **1006** injects electrons and the anode **1004** injects holes. In certain embodiments, the anode **1004** and cathode **1006** are inverted; i.e., the cathode is formed on the substrate **1002** and the anode is opposingly arranged.

Interposed between the cathode **1006** and anode **1004** are one or more organic layers. More specifically, at least one emissive or light emitting layer is interposed between the cathode **1006** and anode **1004**. The light emitting layer may comprise one or more light emitting organic compounds. Typically, the light emitting layer is configured to emit visible light in a single color such as blue, green, red or white. In the illustrated embodiment, one organic layer **1010** is formed between the cathode **1006** and anode **1004** and acts as a light emitting layer. Additional layers, which can be formed between the anode **1004** and cathode **1006**, can include a hole transporting layer, a hole injection layer, an electron transporting layer and an electron injection layer.

Hole transporting and/or injection layers can be interposed between the light emitting layer **1010** and the anode **1004**. Electron transporting and/or injecting layers can be interposed between the cathode **1006** and the light emitting layer **1010**. The electron injection layer facilitates injection of electrons from the cathode **1006** toward the light emitting layer **1010** by reducing the work function for injecting electrons from the cathode **1006**. Similarly, the hole injection layer facilitates injection of holes from the anode **1004** toward the light emitting layer **1010**. The hole and electron transporting layers facilitate movement of the carriers injected from the respective electrodes toward the light emitting layer.

In some embodiments, a single layer may serve both electron injection and transportation functions or both hole injection

and transportation functions. In some embodiments, one or more of these layers are lacking. In some embodiments, one or more organic layers are doped with one or more materials that help injection and/or transportation of the carriers. In embodiments where only one organic layer is formed between the cathode and anode, the organic layer may include not only an organic light emitting compound but also certain functional materials that help injection or transportation of carriers within that layer.

There are numerous organic materials that have been developed for use in these layers including the light emitting layer. Also, numerous other organic materials for use in these layers are being developed. In some embodiments, these organic materials may be macromolecules including oligomers and polymers. In some embodiments, the organic materials for these layers may be relatively small molecules. The skilled artisan will be able to select appropriate materials for each of these layers in view of the desired functions of the individual layers and the materials for the neighboring layers in particular designs.

In operation, an electrical circuit provides appropriate potential between the cathode **1006** and anode **1004**. This results in an electrical current flowing from the anode **1004** to the cathode **1006** via the interposed organic layer(s). In one embodiment, the cathode **1006** provides electrons to the adjacent organic layer **1010**. The anode **1004** injects holes to the organic layer **1010**. The holes and electrons recombine in the organic layer **1010** and generate energy particles called "excitons." The excitons transfer their energy to the organic light emitting material in the organic layer **1010**, and the energy is used to emit visible light from the organic light emitting material. The spectral characteristics of light generated and emitted by the OLED **1000**, **1001** depend on the nature and composition of organic molecules in the organic layer(s). The composition of the one or more organic layers can be selected to suit the needs of a particular application by one of ordinary skill in the art.

OLED devices can also be categorized based on the direction of the light emission. In one type referred to as "top emission" type, OLED devices emit light and display images through the cathode or top electrode **1006**. In these embodiments, the cathode **1006** is made of a material transparent or at least partially transparent with respect to visible light. In certain embodiments, to avoid losing any light that can pass through the anode or bottom electrode **1004**, the anode may be made of a material substantially reflective of the visible light. A second type of OLED devices emits light through the anode or bottom electrode **1004** and is called "bottom emission" type. In the bottom emission type OLED devices, the anode **1004** is made of a material which is at least partially transparent with respect to visible light. Often, in bottom emission type OLED devices, the cathode **1006** is made of a material substantially reflective of the visible light. A third type of OLED devices emits light in two directions, e.g. through both anode **1004** and cathode **1006**. Depending upon the direction(s) of the light emission, the substrate may be formed of a material which is transparent, opaque or reflective of visible light.

In many embodiments, an OLED pixel array **1021** comprising a plurality of organic light emitting pixels is arranged over a substrate **1002** as shown in FIG. 7C. In embodiments, the pixels in the array **1021** are controlled to be turned on and off by a driving circuit (not shown), and the plurality of the pixels as a whole displays information or image on the array **1021**. In certain embodiments, the OLED pixel array **1021** is arranged with respect to other components, such as drive and control electronics to define a display region and a non-

display region. In these embodiments, the display region refers to the area of the substrate **1002** where OLED pixel array **1021** is formed. The non-display region refers to the remaining areas of the substrate **1002**. In embodiments, the non-display region can contain logic and/or power supply circuitry. It will be understood that there will be at least portions of control/drive circuit elements arranged within the display region. For example, in PMOLEDs, conductive components will extend into the display region to provide appropriate potential to the anode and cathodes. In AMOLEDs, local driving circuits and data/scan lines coupled with the driving circuits will extend into the display region to drive and control the individual pixels of the AMOLEDs.

One design and fabrication consideration in OLED devices is that certain organic material layers of OLED devices can suffer damage or accelerated deterioration from exposure to water, oxygen or other harmful gases. Accordingly, it is generally understood that OLED devices be sealed or encapsulated to inhibit exposure to moisture and oxygen or other harmful gases found in a manufacturing or operational environment. FIG. 7D schematically illustrates a cross-section of an encapsulated OLED device **1011** having a layout of FIG. 7C and taken along the line d-d of FIG. 7C. In this embodiment, a generally planar top plate or substrate **1061** engages with a seal **1071** which further engages with a bottom plate or substrate **1002** to enclose or encapsulate the OLED pixel array **1021**. In other embodiments, one or more layers are formed on the top plate **1061** or bottom plate **1002**, and the seal **1071** is coupled with the bottom or top substrate **1002**, **1061** via such a layer. In the illustrated embodiment, the seal **1071** extends along the periphery of the OLED pixel array **1021** or the bottom or top plate **1002**, **1061**.

In embodiments, the seal **1071** is made of a frit material as will be further discussed below. In various embodiments, the top and bottom plates **1061**, **1002** comprise materials such as plastics, glass and/or metal foils which can provide a barrier to passage of oxygen and/or water to thereby protect the OLED pixel array **1021** from exposure to these substances. In embodiments, at least one of the top plate **1061** and the bottom plate **1002** are formed of a substantially transparent material.

To lengthen the life time of OLED devices **1011**, it is generally desired that seal **1071** and the top and bottom plates **1061**, **1002** provide a substantially non-permeable seal to oxygen and water vapor and provide a substantially hermetically enclosed space **1081**. In certain applications, it is indicated that the seal **1071** of a frit material in combination with the top and bottom plates **1061**, **1002** provide a barrier to oxygen of less than approximately  $10^{-3}$  cc/m<sup>2</sup>-day and to water of less than  $10^{-6}$  g/m<sup>2</sup>-day. Given that some oxygen and moisture can permeate into the enclosed space **1081**, in some embodiments, a material that can take up oxygen and/or moisture is formed within the enclosed space **1081**.

The seal **1071** has a width W, which is its thickness in a direction parallel to a surface of the top or bottom substrate **1061**, **1002** as shown in FIG. 7D. The width varies among embodiments and ranges from about 300  $\mu$ m to about 3000  $\mu$ m, optionally from about 500  $\mu$ m to about 1500  $\mu$ m. Also, the width may vary at different positions of the seal **1071**. In some embodiments, the width of the seal **1071** may be the largest where the seal **1071** contacts one of the bottom and top substrate **1002**, **1061** or a layer formed thereon. The width may be the smallest where the seal **1071** contacts the other. The width variation in a single cross-section of the seal **1071** relates to the cross-sectional shape of the seal **1071** and other design parameters.

The seal **1071** has a height H, which is its thickness in a direction perpendicular to a surface of the top or bottom substrate **1061**, **1002** as shown in FIG. 7D. The height varies among embodiments and ranges from about 2  $\mu$ m to about 30  $\mu$ m, optionally from about 10  $\mu$ m to about 15  $\mu$ m. Generally, the height does not significantly vary at different positions of the seal **1071**. However, in certain embodiments, the height of the seal **1071** may vary at different positions thereof.

In the illustrated embodiment, the seal **1071** has a generally rectangular cross-section. In other embodiments, however, the seal **1071** can have other various cross-sectional shapes such as a generally square cross-section, a generally trapezoidal cross-section, a cross-section with one or more rounded edges, or other configuration as indicated by the needs of a given application. To improve hermeticity, it is generally desired to increase the interfacial area where the seal **1071** directly contacts the bottom or top substrate **1002**, **1061** or a layer formed thereon. In some embodiments, the shape of the seal can be designed such that the interfacial area can be increased.

The seal **1071** can be arranged immediately adjacent the OLED array **1021**, and in other embodiments, the seal **1071** is spaced some distance from the OLED array **1021**. In certain embodiment, the seal **1071** comprises generally linear segments that are connected together to surround the OLED array **1021**. Such linear segments of the seal **1071** can extend, in certain embodiments, generally parallel to respective boundaries of the OLED array **1021**. In other embodiment, one or more of the linear segments of the seal **1071** are arranged in a non-parallel relationship with respective boundaries of the OLED array **1021**. In yet other embodiments, at least part of the seal **1071** extends between the top plate **1061** and bottom plate **1002** in a curvilinear manner.

As noted above, in certain embodiments, the seal **1071** is formed using a frit material or simply "frit" or glass frit," which includes fine glass particles. The frit particles includes one or more of magnesium oxide (MgO), calcium oxide (CaO), barium oxide (BaO), lithium oxide (Li<sub>2</sub>O), sodium oxide (Na<sub>2</sub>O), potassium oxide (K<sub>2</sub>O), boron oxide (B<sub>2</sub>O<sub>3</sub>), vanadium oxide (V<sub>2</sub>O<sub>5</sub>), zinc oxide (ZnO), tellurium oxide (TeO<sub>2</sub>), aluminum oxide (Al<sub>2</sub>O<sub>3</sub>), silicon dioxide (SiO<sub>2</sub>), lead oxide (PbO), tin oxide (SnO), phosphorous oxide (P<sub>2</sub>O<sub>5</sub>), ruthenium oxide (Ru<sub>2</sub>O), rubidium oxide (Rb<sub>2</sub>O), rhodium oxide (Rh<sub>2</sub>O), ferrite oxide (Fe<sub>2</sub>O<sub>3</sub>), copper oxide (CuO), titanium oxide (TiO<sub>2</sub>), tungsten oxide (WO<sub>3</sub>), bismuth oxide (Bi<sub>2</sub>O<sub>3</sub>), antimony oxide (Sb<sub>2</sub>O<sub>3</sub>), lead-borate glass, tin-phosphate glass, vanadate glass, and borosilicate, etc. In embodiments, these particles range in size from about 2  $\mu$ m to about 30  $\mu$ m, optionally about 5  $\mu$ m to about 10  $\mu$ m, although not limited only thereto. The particles can be as large as about the distance between the top and bottom substrates **1061**, **1002** or any layers formed on these substrates where the frit seal **1071** contacts.

The frit material used to form the seal **1071** can also include one or more filler or additive materials. The filler or additive materials can be provided to adjust an overall thermal expansion characteristic of the seal **1071** and/or to adjust the absorption characteristics of the seal **1071** for selected frequencies of incident radiant energy. The filler or additive material(s) can also include inversion and/or additive fillers to adjust a coefficient of thermal expansion of the frit. For example, the filler or additive materials can include transition metals, such as chromium (Cr), iron (Fe), manganese (Mn), cobalt (Co), copper (Cu), and/or vanadium. Additional materials for the filler or additives include ZnSiO<sub>4</sub>, PbTiO<sub>3</sub>, ZrO<sub>2</sub>, eucryptite.

In embodiments, a frit material as a dry composition contains glass particles from about 20 to 90 about wt %, and the remaining includes fillers and/or additives. In some embodiments, the frit paste contains about 10-30 wt % organic materials and about 70-90% inorganic materials. In some embodiments, the frit paste contains about 20 wt % organic materials and about 80 wt % inorganic materials. In some embodiments, the organic materials may include about 0-30 wt % binder(s) and about 70-100 wt % solvent(s). In some embodiments, about 10 wt % is binder(s) and about 90 wt % is solvent(s) among the organic materials. In some embodiments, the inorganic materials may include about 0-10 wt % additives, about 20-40 wt % fillers and about 50-80 wt % glass powder. In some embodiments, about 0-5 wt % is additive(s), about 25-30 wt % is filler(s) and about 65-75 wt % is the glass powder among the inorganic materials.

In forming a frit seal, a liquid material is added to the dry frit material to form a frit paste. Any organic or inorganic solvent with or without additives can be used as the liquid material. In embodiments, the solvent includes one or more organic compounds. For example, applicable organic compounds are ethyl cellulose, nitro cellulose, hydroxyl propyl cellulose, butyl carbitol acetate, terpineol, butyl cellulosive, acrylate compounds. Then, the thus formed frit paste can be applied to form a shape of the seal **1071** on the top and/or bottom plate **1061**, **1002**.

In one exemplary embodiment, a shape of the seal **1071** is initially formed from the frit paste and interposed between the top plate **1061** and the bottom plate **1002**. The seal **1071** can in certain embodiments be pre-cured or pre-sintered to one of the top plate and bottom plate **1061**, **1002**. Following assembly of the top plate **1061** and the bottom plate **1002** with the seal **1071** interposed therebetween, portions of the seal **1071** are selectively heated such that the frit material forming the seal **1071** at least partially melts. The seal **1071** is then allowed to resolidify to form a secure joint between the top plate **1061** and the bottom plate **1002** to thereby inhibit exposure of the enclosed OLED pixel array **1021** to oxygen or water.

In embodiments, the selective heating of the frit seal is carried out by irradiation of light, such as a laser or directed infrared lamp. As previously noted, the frit material forming the seal **1071** can be combined with one or more additives or filler such as species selected for improved absorption of the irradiated light to facilitate heating and melting of the frit material to form the seal **1071**.

In some embodiments, OLED devices **1011** are mass produced. In an embodiment illustrated in FIG. 7E, a plurality of separate OLED arrays **1021** is formed on a common bottom substrate **1101**. In the illustrated embodiment, each OLED array **1021** is surrounded by a shaped frit to form the seal **1071**. In embodiments, common top substrate (not shown) is placed over the common bottom substrate **1101** and the structures formed thereon such that the OLED arrays **1021** and the shaped frit paste are interposed between the common bottom substrate **1101** and the common top substrate. The OLED arrays **1021** are encapsulated and sealed, such as via the previously described enclosure process for a single OLED display device. The resulting product includes a plurality of OLED devices kept together by the common bottom and top substrates. Then, the resulting product is cut into a plurality of pieces, each of which constitutes an OLED device **1011** of FIG. 7D. In certain embodiments, the individual OLED devices **1011** then further undergo additional packaging operations to further improve the sealing formed by the frit seal **1071** and the top and bottom substrates **1061**, **1002**.

A glass frit may be formed in a height of about 14  $\mu\text{m}$  or less. Here, the height refers to the length or thickness of the frit in the direction interconnecting the top and bottom substrates. The top substrate may form a curvature, in which the central portion of the top substrate droops toward the bottom substrate due to its own weight by about 7 to 8  $\mu\text{m}$ . As a result, the air gap between the top substrate and the pixel array may not be uniform, which can cause Newton's rings on the display surface. FIG. 1 shows Newton's rings in an organic light emitting display device (OLED).

FIGS. 2 and 3 are cross-sectional views of an organic light emitting display device (OLED) according to an exemplary embodiment of the present invention. Referring to FIG. 2, a substrate **200** is equivalent to the bottom plate **1002**. The substrate **200** may be an insulating substrate, such as a glass substrate and a plastic substrate, or a conductive substrate. Subsequently, an organic light emitting diode or pixel **210** is formed on the substrate **200**. The organic light emitting diode **210** may include a first electrode, an organic layer having at least an emission layer (EML), and a second electrode.

In the organic light emitting diode or pixel **210**, the first electrode may be formed of indium tin oxide (ITO) or indium zinc oxide (IZO). Also, when the OLED is a top-emitting OLED, the organic light emitting diode **210** may further include a reflective layer. The organic layer includes at least the EML and may further include at least one of a hole injection layer (HIL), a hole transport layer (HTL), an electron transport layer (ETL), and an electron injection layer (EIL). The second electrode may be formed of a material having a small work function, e.g., at least one selected from the group consisting of Mg, Ag, Al, Ca, and an alloy thereof. Also, the organic light emitting diode **210** may further include a thin film transistor (TFT) having a semiconductor layer, a gate electrode, and source and drain electrodes. The TFT may be a top gate type TFT in which a gate electrode is formed on a semiconductor layer or a bottom gate type TFT in which a gate electrode is formed under a semiconductor layer.

Referring to FIG. 3, an encapsulation substrate **220**, which is equivalent to the top plate **1061**, is provided opposite to the substrate **200**. The encapsulation substrate **220** may be a flat insulating glass substrate. A sealant **230** is formed on the edge of the encapsulation substrate **220**. In this case, when the sealant **230** is formed such that, when the substrate **200** is bonded with the encapsulation substrate **220**, an air gap "d" between central portions of the substrate **200** and the encapsulation substrate **220** ranges from about 10 to about 300  $\mu\text{m}$ . In one embodiment, the sealant **230** may be formed of an ultraviolet (UV) curable material, for example, acryl-based resin or polyimide-based resin.

In another embodiment, the sealant **230** can be a glass frit. The glass frit may be formed of one selected from the group consisting of magnesium oxide (MgO), calcium oxide (CaO), barium oxide (BaO), lithium oxide (Li<sub>2</sub>O), sodium oxide (Na<sub>2</sub>O), potassium oxide (K<sub>2</sub>O), boron oxide (B<sub>2</sub>O<sub>3</sub>), vanadium oxide (V<sub>2</sub>O<sub>5</sub>), zinc oxide (ZnO), tellurium oxide (TeO<sub>2</sub>), aluminum oxide (Al<sub>2</sub>O<sub>3</sub>), silicon dioxide (SiO<sub>2</sub>), lead oxide (PbO), tin oxide (SnO), phosphorous oxide (P<sub>2</sub>O<sub>5</sub>), ruthenium oxide (Ru<sub>2</sub>O), rubidium oxide (Rb<sub>2</sub>O), rhodium oxide (Rh<sub>2</sub>O), ferrite oxide (Fe<sub>2</sub>O<sub>3</sub>), copper oxide (CuO), titanium oxide (TiO<sub>2</sub>), tungsten oxide (WO<sub>3</sub>), bismuth oxide (Bi<sub>2</sub>O<sub>3</sub>), antimony oxide (Sb<sub>2</sub>O<sub>3</sub>), lead-borate glass, tin-phosphate glass, vanadate glass, and borosilicate, and a combination thereof. Also, the glass frit may be formed on the edge of the encapsulation substrate **220** or the edge of the substrate **200** by a screen printing method or a dispensing method.

The organic light emitting display device has a gap between the the top surface of the pixel array and the inner surface of the encapsulation substrate. Generally, the size of the gap depends on the height of the seal interconnecting two substrates. The frit seal, among other forms of sealing, allows the gap size significantly smaller than others. For example, when using frit seal, the gap size (the distance between the array and the encapsulation substrate) can be in the order of a few  $\mu\text{m}$  to several hundred  $\mu\text{m}$ . When the gap size is in this range, dark rings called Newton's rings may be formed on the display surface due to optical interference created by light incident to the display surface. More specifically, when the gap size is about or less than  $10\ \mu\text{m}$ , the possibility of Newton's rings increases. Thus, in packaging an organic light emitting display device with the frit seal, the size of the gap can be a design factor in view of the Newton's rings. In one embodiment, the gap size is greater than about  $10\ \mu\text{m}$ . Optionally, the gap size is from about  $10$  to about  $300\ \mu\text{m}$ , further optionally from about  $10$  to about  $30\ \mu\text{m}$ . In certain embodiments, the gap size is about  $10, 11, 12, 13, 14, 15, 16, 17, 18, 19, 20, 21, 22, 23, 24, 25, 26, 27, 28, 29, 30, 32, 34, 36, 38, 40, 43, 46, 50, 55, 60, 65, 70, 80, 90, 100, 120, 150, 200, 250$  or  $300\ \mu\text{m}$ .

In one embodiment, the substrate **200** on which the organic light emitting diode **210** is formed and the encapsulation substrate **220** on which the sealant **230** is formed are aligned and then bonded to each other. In this case, the substrate **200** and the encapsulation substrate **220** are bonded to each other such that the air gap "d" between a top surface of the substrate **200** on which an array of the organic light emitting diodes or pixels **210** is formed and the central portion of the encapsulation substrate **220** is about  $10\ \mu\text{m}$  or more, preferably, ranges from about  $10$  to about  $300\ \mu\text{m}$ . In this case, the sealant **230**, which is formed of a UV curable material or glass frit, may have a height  $h$  of  $10$  to  $300\ \mu\text{m}$ .

Subsequently, in one embodiment, when the sealant **230** includes the UV curable material, the UV curable material is cured with UV irradiation. Also, in an embodiment, when the sealant **230** is the glass frit, the glass frit is melted by laser irradiation and solidified. Thereby, the OLED according to an embodiment of the present invention is completed.

In the OLED fabricated according to the exemplary embodiment of the present invention, the substrate **200** on which the organic light emitting diode **210** is formed is bonded to the encapsulation substrate **200** such that the air gap "d" between the top surface of the substrate **200**, particularly at the central portions of the substrate **200**, and the encapsulation substrate **220** ranges from about  $10$  to about  $300\ \mu\text{m}$ , thereby preventing Newton's rings from occurring and thereby improving image quality.

FIGS. **4** and **5** are cross-sectional views of an OLED according to another exemplary embodiment of the present invention. Referring to FIG. **4**, a substrate **300** is provided. The substrate **300** may be an insulating substrate, such as a glass substrate or a plastic substrate, or a conductive substrate. Subsequently, an organic light emitting diode **310** is formed on the substrate **300**. The organic light emitting diode **310** may include a first electrode, an organic layer having at least an EML, and a second electrode.

In the organic light emitting diode **310**, the first electrode may be formed of ITO or IZO. Also, when the OLED is a top-emitting OLED, the organic light emitting diode **310** may further include a reflective layer. The organic layer includes at least the EML and may further include at least one of a hole injection layer (HIL), a hole transport layer (HTL), an electron transport layer (ETL), and an electron injection layer (EIL). The second electrode may be formed of a material

having a small work function, e.g., at least one selected from the group consisting of Mg, Ag, Al, Ca, and an alloy thereof. Also, the organic light emitting diode **310** may further include a TFT having a semiconductor layer, a gate electrode, and source and drain electrodes. The TFT may be a top gate type TFT in which a gate electrode is formed on a semiconductor layer or a bottom gate type TFT in which a gate electrode is formed under a semiconductor layer.

Referring to FIG. **5**, an encapsulation substrate **320** is provided opposite to the substrate **300**. The encapsulation substrate **320** may be an etched insulating glass substrate. Specifically, when the encapsulation substrate **320** is bonded to the substrate **300** later, the encapsulation substrate **320** may be etched such that an air gap "d" between a top surface of the substrate **300** and a central portion of the encapsulation substrate **320** ranges about  $10$  to about  $300\ \mu\text{m}$ . By etching the encapsulation substrate **320** in order to keep the air gap "d" between the top surface of the substrate **300** and the central portion of the encapsulation substrate **320** about  $10\ \mu\text{m}$  or more, the glass frit can have a small height.

Thereafter, a glass frit **330** is formed on the edge of the encapsulation substrate **320**. The glass frit **330** may be formed of one selected from the group consisting of magnesium oxide (MgO), calcium oxide (CaO), barium oxide (BaO), lithium oxide (Li<sub>2</sub>O), sodium oxide (Na<sub>2</sub>O), potassium oxide (K<sub>2</sub>O), boron oxide (B<sub>2</sub>O<sub>3</sub>), vanadium oxide (V<sub>2</sub>O<sub>5</sub>), zinc oxide (ZnO), tellurium oxide (TeO<sub>2</sub>), aluminum oxide (Al<sub>2</sub>O<sub>3</sub>), silicon dioxide (SiO<sub>2</sub>), lead oxide (PbO), tin oxide (SnO), phosphorous oxide (P<sub>2</sub>O<sub>5</sub>), ruthenium oxide (Ru<sub>2</sub>O), rubidium oxide (Rb<sub>2</sub>O), rhodium oxide (Rh<sub>2</sub>O), ferrite oxide (Fe<sub>2</sub>O<sub>3</sub>), copper oxide (CuO), titanium oxide (TiO<sub>2</sub>), tungsten oxide (WO<sub>3</sub>), bismuth oxide (Bi<sub>2</sub>O<sub>3</sub>), antimony oxide (Sb<sub>2</sub>O<sub>3</sub>), lead-borate glass, tin-phosphate glass, vanadate glass, and borosilicate, and a combination thereof. Also, the glass frit **330** may be formed on the edge of the encapsulation substrate **320** or the edge of the substrate **300** by a screen printing method or a dispensing method.

Thereafter, the substrate **300** on which the organic light emitting diode **310** is formed and the encapsulation substrate **320** on which the glass frit **330** is formed are aligned and then bonded to each other. In an embodiment, the substrate **300** and the encapsulation substrate **320** are bonded to each other such that the air gap "d" between the top surface of the substrate **300** on which the organic light emitting diode **310** is formed and the central portion of the encapsulation substrate **320** is about  $10\ \mu\text{m}$  or more, preferably, ranges from about  $10$  to about  $300\ \mu\text{m}$ . In an embodiment, the height  $h$  of the glass frit **330** may range from about  $10$  to about  $300\ \mu\text{m}$ . Also, since the glass frit **330** with the height of about  $300\ \mu\text{m}$  or less can be formed by melting by laser irradiation and solidifying.

Subsequently, the glass frit **330** is melted by laser irradiation and solidified, so that the OLED according to another exemplary embodiment of the present invention can be completed. In the OLED according to another exemplary embodiment of the present invention, the encapsulation substrate **320** may be etched such that the air gap "d" between the central portions of the substrate **300** and the encapsulation substrate **320** ranges from about  $10$  to about  $300\ \mu\text{m}$ , thereby preventing Newton's rings from occurring and improving image quality.

Hereinafter, an experimental example is presented. However, the present invention should not be construed as being limited to the experimental example set forth herein. Rather, the experimental example is provided to facilitate understanding.

#### EXAMPLE

FIG. **6** is a graph of luminance versus an air gap between a substrate and an encapsulation substrate. In FIG. **6**, an

abscissa denotes an air gap “d” between the top surface of an array at the central portions of a substrate on which the array of organic light emitting diodes is formed and an encapsulation substrate, which is expressed in nanometers (nm), and an ordinate denotes luminance of Newton’s rings versus the air gap “d”. Referring to FIG. 6, it can be seen that as the air gap “d” between the substrate on which the organic light emitting diode is formed and the encapsulation substrate increases, variation in the intensity of the Newton’s rings, which is shown as amplitude, gradually decreases. Further, when the air gap “d” between the substrate and the encapsulation substrate exceeds about 10000 nm (i.e., 10 μm), the amplitude becomes fine.

Specifically, light reflected on the encapsulation substrate interferes with light that passes through the encapsulation substrate and is reflected on the substrate on which the organic light emitting diode is formed, so that destructive interference causes dark patterns, and constructive interference causes bright patterns. In this case, repetition of the dark and bright patterns is referred to as a Newton’s rings. Thus, the amplitude refers to a difference in luminance between the dark and bright patterns of the Newton’s rings. Accordingly, a reduction in the amplitude can be understood as a reduction in a difference in luminance between the dark and bright patterns of the Newton’s rings.

Therefore, when the air gap “d” between the top surface of the substrate on which the organic light emitting diode is formed and the encapsulation substrate is more than about 10000 nm (i.e., 10 μm), the amplitude is scarcely distinguishable by the naked eye. Thus, the Newton’s rings cannot be easily observed by the naked eye. Based on the above-described result, it can be concluded that when the air gap “d” between the central portions of the substrate on which the organic light emitting diode is formed and the encapsulation substrate is made to about 10 μm or more, the Newton’s rings can be prevented. As described above, an OLED and a method of fabricating the same according to the present invention can prevent Newton’s rings to improve image quality when a substrate and an encapsulation substrate are bonded to each other.

Although the present invention has been described with reference to certain exemplary embodiments thereof, it will be understood by those skilled in the art that a variety of modifications and variations may be made to the present invention without departing from the spirit or scope of the present invention defined in the appended claims, and their equivalents.

What is claimed is:

1. An organic light emitting display device, comprising:  
 a first substrate comprising a single layer or multiple layers;  
 a second substrate comprising a single layer or multiple layers, the second substrate comprising an inner surface facing the first substrate;  
 an array of organic light emitting pixels formed on the first substrate and interposed between the first and second substrates, the array comprising a top surface opposing the inner surface of the second substrate, wherein the top surface and the inner surface has a gap therebetween, and the gap has a gap distance measured between the top surface and the inner surface wherein the gap distance is equal to or greater than 10 μm, said array comprising elongate strips of anode and elongate strips of cathode where the elongate strips of anode are arranged generally perpendicular to the elongate strips of cathode, and wherein each pixel is defined by the intersections of the

elongate strips of anode and the elongate strips of cathode and an organic layer interposed therebetween; and a frit seal interconnecting the first and second substrates while surrounding the array, wherein the frit seal, the first substrate and the second substrate in combination define an enclosed space in which the array is located, wherein the frit seal has a height between the first and second substrates from about 2 to about 300 μm and the frit seal is prepared from a frit paste comprising about 10-30 wt % organic materials and about 70-90 wt % inorganic materials where the organic materials comprise 0-30 wt % binder(s) and about 70-100 wt % solvent (s), and wherein the enclosed space does not include a desiccant.

2. The device of claim 1, wherein the gap distance is about 10 to about 300 μm.

3. The device of claim 1, wherein the gap distance is from about 10 to about 100 μm.

4. The device of claim 1, wherein the gap distance is from about 10 to about 30 μm.

5. The device of claim 1, wherein the array is configured to emit visible light through the top surface.

6. The device of claim 1, wherein the inner surface of the second substrate is uncoated.

7. The device of claim 1, wherein the second substrate comprises a display surface facing away from the first substrate and configured to display an image thereon, and wherein the device is configured to display an image on the display surface substantially free of Newton’s rings.

8. The device of claim 1, wherein the array comprises a first electrode, a second electrode and at least one organic layer interposed therebetween, wherein the second electrode is closer to the second substrate than the first electrode, and wherein the top surface comprises a surface of the second electrode facing the second substrate.

9. The device of claim 1, wherein the array comprises a first electrode, a second electrode and at least one organic layer interposed therebetween, wherein the second electrode is closer to the second substrate than the first electrode, wherein the array further comprises a substantially transparent layer formed on the second electrode, and wherein the top surface comprises a surface of the substantially transparent layer which faces the second substrate.

10. The device of claim 1, wherein the gap comprises an air gap.

11. The device of claim 1, wherein the gap is substantially filled with a solid material.

12. The device of claim 1, wherein the inorganic materials consist of one or more materials selected from the group consisting of magnesium oxide (MgO), calcium oxide (CaO), barium oxide (BaO), sodium oxide (Na<sub>2</sub>O), tellurium oxide (TeO<sub>2</sub>), ruthenium oxide (Ru<sub>2</sub>O), rubidium oxide (Rb<sub>2</sub>O), rhodium oxide (Rh<sub>2</sub>O), copper oxide (CuO), tin-phosphate glass, and borosilicate.

13. An organic light emitting display device, comprising:  
 a first substrate;

a second substrate comprising an inner surface facing the first substrate;

an array of organic light emitting pixels formed on the first substrate, the array comprising a top surface opposing the inner surface of the second substrate, wherein the top surface and the inner surface has a gap therebetween from about 10 to about 300 μm, said array comprising elongate strips of anode and elongate strips of cathode where the elongate strips of anode are arranged generally perpendicular to the elongate strips of cathode, and wherein each pixel is defined by the intersections of the

15

elongate strips of anode and the elongate strips of cathode and an organic layer interposed therebetween; and a frit seal interconnecting the first and second substrates while surrounding the array, wherein the frit seal, the first substrate and the second substrate in combination 5 define an enclosed space in which the array is located and the frit seal is prepared from a frit paste comprising about 10-30 wt % organic materials and about 70-90 wt % inorganic materials where the organic materials comprise 0-30 wt % binder(s) and about 70-100 wt % solvent 10 (s), wherein the enclosed space does not include a desiccant.

14. The device of claim 1, wherein the frit seal has a width of about 300  $\mu\text{m}$ .

15. The device of claim 1, wherein the frit seal has a width of about 3000  $\mu\text{m}$ .

16. The device of claim 1, wherein the frit seal has a width of about 1500  $\mu\text{m}$ .

17. The device of claim 1, wherein the frit seal has a width of about 500  $\mu\text{m}$ .

18. The device of claim 8, wherein the first electrode is formed of indium zinc oxide.

19. An organic light emitting display device, comprising: a first substrate comprising a single layer or multiple layers; 25

a second substrate comprising a single layer or multiple layers, the second substrate comprising an inner surface facing the first substrate, wherein the inner surface of the second substrate is uncoated;

16

an array of organic light emitting pixels formed on the first substrate and interposed between the first and second substrates, the array comprising a top surface opposing the inner surface of the second substrate, wherein the top surface and the inner surface has a gap therebetween, and the gap has a gap distance measured between the top surface and the inner surface wherein the gap distance is about 10 to about 300  $\mu\text{m}$ , and wherein each pixel comprises a cathode, an anode and an organic layer interposed therebetween;

a driving circuit;

a scan line;

a data line, where the driving circuit is coupled with the data line and the scan line, and the scan line is between the driving circuit and the anode; and

15 a frit seal interconnecting the first and second substrates while surrounding the array, wherein the frit seal, the first substrate and the second substrate in combination define an enclosed space in which the array is located, wherein the frit seal has a height between the first and second substrates from about 2 to about 300  $\mu\text{m}$  and the frit seal is prepared from a frit paste comprising about 10-30 wt % organic materials and about 70-90 wt % inorganic materials where the organic materials comprise 0-30 wt % binder(s) and about 70-100 wt % solvent 20 (s), and wherein the enclosed space does not include a desiccant.

20. The device of claim 19, wherein the frit seal has a height between the first and second substrates from 2 to 10  $\mu\text{m}$ .

\* \* \* \* \*

UNITED STATES PATENT AND TRADEMARK OFFICE  
**CERTIFICATE OF CORRECTION**

PATENT NO. : 8,729,796 B2  
APPLICATION NO. : 11/529891  
DATED : May 20, 2014  
INVENTOR(S) : Choi et al.

Page 1 of 2

It is certified that error appears in the above-identified patent and that said Letters Patent is hereby corrected as shown below:

On the Title Page

Insert --(30) **Foreign Application Priority Data**

Jan. 25, 2006 (KR).....10-2006-0007963--.

In column 1 (page 4, item 56) at line 12, Under OTHER PUBLICATIONS, change  
“Japanese” to --Japanese--.

In column 1 (page 4, item 56) at line 70, Under OTHER PUBLICATIONS, change “Sep. 20,  
2006,” to --Sep. 29, 2006,--.

In column 2 (page 4, item 56) at line 14, Under OTHER PUBLICATIONS, change  
“potentially” to --potentially--.

In column 2 (page 4, item 56) at lines 23-24, Under OTHER PUBLICATIONS, change  
“2007/0170857” to --2007/0170859--.

In column 2 (page 4, item 56) at lines 27-28, Under OTHER PUBLICATIONS, change  
“2007/0170859” to --2007/0170860--.

In column 2 (page 4, item 56) at line 28, Under OTHER PUBLICATIONS, change  
“prosecution” to --prosecution--.

In column 2 (page 4, item 56) at line 29, Under OTHER PUBLICATIONS, change  
“limitaton” to --limitation--.

In column 2 (page 4, item 56) at lines 31-32, Under OTHER PUBLICATIONS, change  
“2007/0170860” to --2007/0170861--.

In column 2 (page 4, item 56) at lines 43-44, Under OTHER PUBLICATIONS, change  
“2007/0167549” to --2007/0176549--.

In column 2 (page 4, item 56) at line 52, Under OTHER PUBLICATIONS, change  
“prosectuion” to --prosecution--.

Signed and Sealed this  
Eleventh Day of November, 2014



Michelle K. Lee  
Deputy Director of the United States Patent and Trademark Office

**CERTIFICATE OF CORRECTION (continued)**

**U.S. Pat. No. 8,729,796 B2**

In the Specification

In column 9 at line 24, Change "cellusolve," to --cellosolve,--.

In column 11 at line 2, Change "the the" to --the--.

专利名称(译)	有机发光显示装置包括用于改善图像质量的间隙及其制造方法		
公开(公告)号	<a href="#">US8729796</a>	公开(公告)日	2014-05-20
申请号	US11/529891	申请日	2006-09-29
[标]申请(专利权)人(译)	崔东SOO 朴镇宇 JEONG HEE SEONG 朴炫SOOK		
申请(专利权)人(译)	崔东SOO 朴镇宇 JEONG HEE SEONG 朴炫淑		
当前申请(专利权)人(译)	三星DISPLAY CO. , LTD.		
[标]发明人	CHOI DONG SOO PARK JIN WOO JEONG HEE SEONG PARK HYUN SOOK		
发明人	CHOI, DONG-SOO PARK, JIN-WOO JEONG, HEE-SEONG PARK, HYUN-SOOK		
IPC分类号	H01L51/50 H01L51/52		
CPC分类号	H01L51/524 H01L51/5246 H01L51/5281 H01L27/3281 B08B3/041 G02F1/1303 G02F2001/1316		
优先权	1020060007963 2006-01-25 KR		
其他公开文献	US20070170855A1		
外部链接	<a href="#">Espacenet</a> <a href="#">USPTO</a>		

摘要(译)

提供一种用于防止牛顿环改善图像质量的有机发光显示装置 ( OLED )。根据本发明的一个实施例的有机发光显示装置包括：第一基板，包括单层或多层；第二基板，包括单层或多层，第二基板包括面向第一基板的内表面；形成在第一基板上并介于第一和第二基板之间的有机发光像素阵列，该阵列包括与第二基板的内表面相对的顶表面，其中顶表面和内表面之间具有间隙，并且间隙具有在顶表面和内表面之间测量的间隙距离；以及在围绕所述阵列时互连所述第一和第二基板的玻璃料密封，其中所述玻璃料密封，所述第一基板和所述第二基板组合形成所述阵列所在的封闭空间，其中所述玻璃料密封具有在所述第一基板之间的高度和第二基板，以形成等于或大于约10μm的间隙距离。

